

- Sampling Conditioning Systems
- Process Analytics
- System Integration
- Gas Generators
- FTIR-Analysers

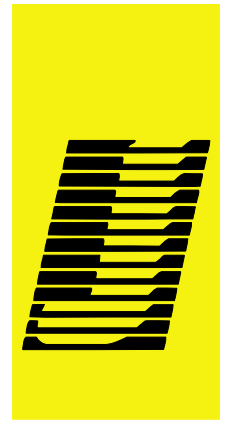

conditioning systems

# Portable Gas Conditioner JCC



## FEATURES

- ◆ Stable dew point +3°C
- ◆ Ambient temperature +5 ... +45°C (50°C)
- ◆ Proportional temperature & pressure control
- ◆ Built-in pump & condensate discharge pump
- ◆ Digital temperature display and flowmeter
- ◆ High performance heat exchanger
- ◆ Proven and reliable technology
- ◆ Compact and robust
- ◆ Environment-friendly (CFC free)

## APPLICATION

The JCC Portable Sample Gas Conditioner is designed to lower the sample dew point and supply dehumidified sample gas with a pump to the moisture intolerant analysis equipment. The operation capability at high ambient temperature also enables applications i.e. in boiler houses.

## TECHNOLOGY

A constant dew point independent of varying sample specifications and ambient temperature is ensured by an improved proportional temperature and pressure control. The cooling system features a continuously running non-CFC compressor motor filled

with environmentally friendly R134a. The high performance heat exchanger guarantees maximum heat transfer rate and leak free operation. A built-in condensate discharge pump removes continuously the condensate and respectively a sample filter the impurities.

## FEATURES

The JCC Portable Sample Gas Conditioner features a single or dual gas path made of PVDF. A flowmeter allows the adjustment of the required flow rate. A digital temperature display, a temperature alarm and interlocked pump provide unattended trouble free operation.

## TECHNICAL DATA

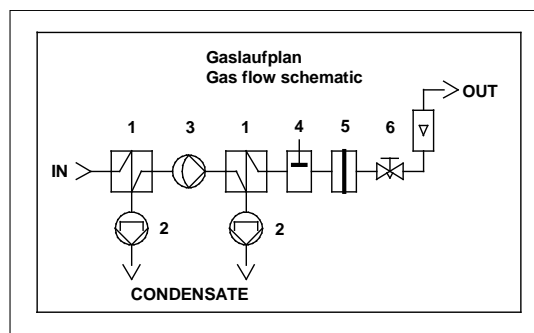
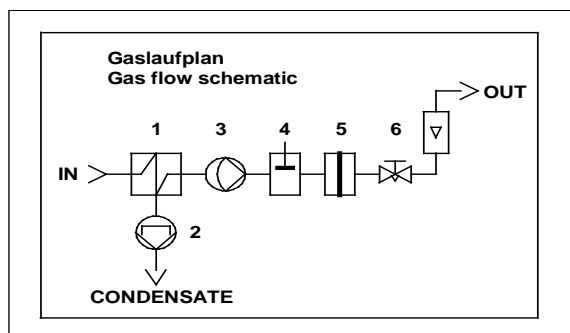

### Gas flow

- 1 Heat Exchanger
- 2 Peristaltic Pump
- 3 Diaphragm Pump
- 4 Condensate sensor (Option)
- 5 Filter
- 6 Flowmeter needle valve

### Abmessungen

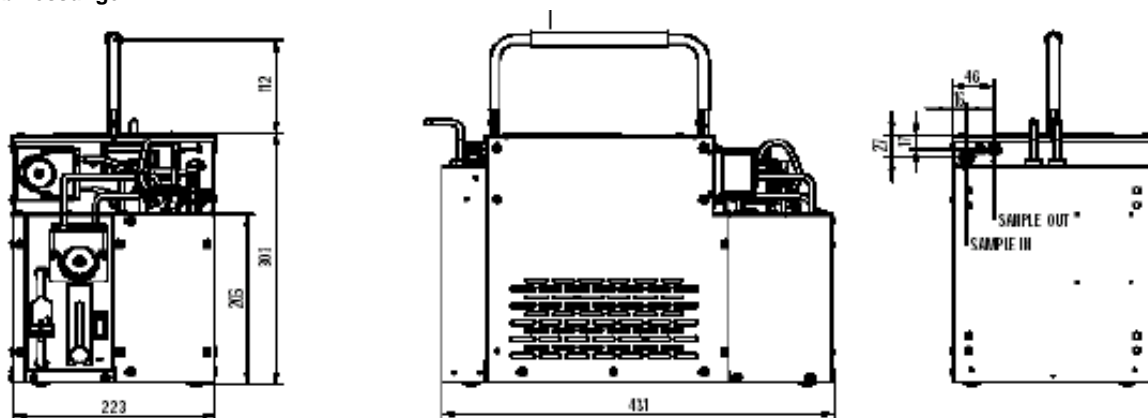

SPECIFICATIONS	
Gas flow rate	100NI/h 1 gas path 200NI/h 2 gas paths
Gas inlet dew point	max. 65°C
Gas inlet temperature	max. 140°C
Gas outlet dew point	+3°C (factory set point)
Dew point stability	+/- 0.2°C @ 20°C DP in 60°C
Ambient temperature	+5 ... +45°C (50°C)
Cooling power	160W at ambient 25°C; Evaporation temperature 0°C
Dead volume	max. 160ccm
Condensate discharge	1 condensate pump / gas path Capacity 300ml/h
Gas filter	One way filter 1µm Nylon/ Borosilicatefibre

SPECIFICATIONS	
Flow meter	with needle valve PP/Glass/PVDF
Flow meter range	10...100NI/h / 15...150NL/h
Operating control	Digital indication of heat exchanger temperature
Safety features	Built-in temp. Alarm and pump will be interlocked at >8°C
Gas connection	Gas inlet: Fitting DN 4/6 SS-Swagelok Gas outlet: Fitting DN 4/6 PP
Mains	2x3p cable 2m; mains; status
Housing	Steel sheet; coated RAL 7035
Dimension	430x225x300mm (WxDXH)
Weight	max. 20kg

## ORDER CODE

Order code		22.									
Basic Unit	Transportable with 1 evaporator	P									
Evaporator 1	1 Mono heat-exchanger PVDF, 1 condensate pump		1								
	1 Dual heat-exchanger PVDF, 2 condensate pumps		4								
Fine dust filter	Fine dust filter—one way			1							
	Fine dust filter JF-1 incl filter element			2							
Gas sample pump	< 200NI/h				2						
Gas flow control	Flow meter with needle valve made of PVDF 15...150 NI/h					3					
	Flow meter with needle valve made of PVDF 10...100 NI/h					4					
Condensate detector	Without condensate sensor KW-2						0				
	with condensate sensor KW-2						1				
Power supply	230V 50Hz								1		
	230V 60Hz								2		
	115V 50Hz								3		
	115V 60Hz								4		
Order code		22.									

Specification subject to change without notice.

PDS\_E\_JCC-PT\_v1.8

### **JCT** Analysentechnik GmbH

Werner Heisenberg-Straße 4 A-2700 Wiener Neustadt  
 Tel. +43 (0) 2622 / 87201 Fax +43 (0) 2622 / 872011  
 E-Mail: [sales@jct.at](mailto:sales@jct.at) Web: [www.jct.at](http://www.jct.at)

