

- Sampling Conditioning Systems
- Process Analytics
- System Integration
- Gas Generators
- FTIR-Analysers

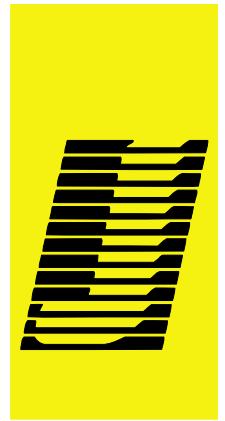

conditioning systems

Gas Sampling Probe JES 301Ex

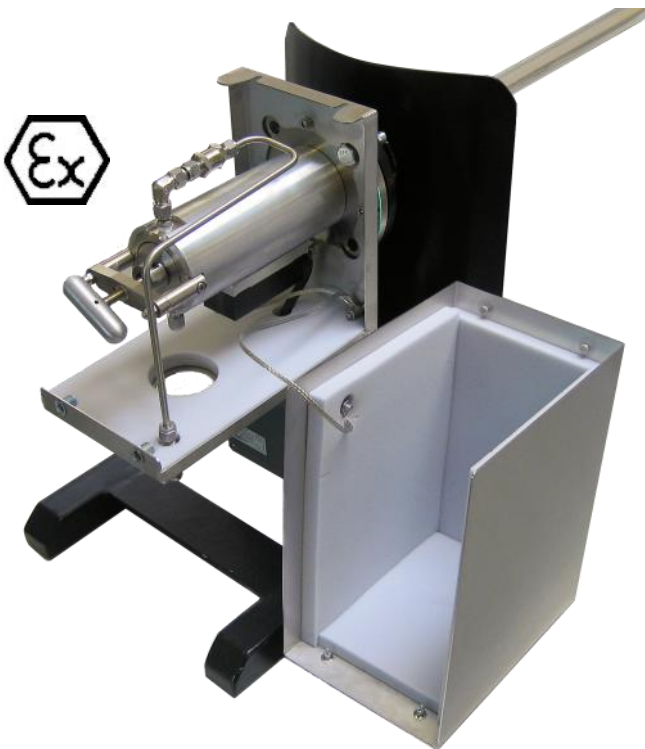

FEATURES

- ◆ EX version - zone 1 or zone 2
- ◆ Rugged construction
- ◆ Easy filter replacement
- ◆ Low maintenance
- ◆ Self limited Ex-heater
- ◆ Calibration gas inlet (option)
- with non return valve
- ◆ Back purge (option)

APPLICATION

The gas sampling probes JES 301E1 and JES 301E2 are for continuous use with extractive sampling systems even where the sample contains dust and aerosols in Zone 1 or Zone 2.

The JES 301Ex is available in several versions which may be custom configured to meet user's specific requirements. Versions include back purge option, calibration gas inlet with Non Return Valve (NRV) on the sample inlet and a combination of both of these.

The JES 301Ex incorporates a non-corrosive heated, replaceable ceramic filter element with a filter porosity of 2 micron. The filter element is mounted in an electrically heated stainless steel housing, which is installed in a thermally isolated weather protection housing.

The heated line series JH can be easily connected to the JES 301Ex by a movable PG42 fastening screw.

TECHNOLOGY

The gas sampling probe series JES 301Ex complete unit, consisting of the heated filter head, mounting flange and probe assembly, can be mounted anywhere horizontally or vertically. The probe can be connected with a standard DN65 PN6, Form B flange directly. The flange material is stainless steel. When mounted horizontally, the JES 301Ex should be inclined at an angle of 5° to 15° to allow any condensate formed to drain away from the filter head. A broad range of different materials for In-Situ probe tubes, and large In-Situ - pre filters make the JES 301Ex versatile in application.

FEATURES

The unit is extremely robust and well engineered to provide many years operational service in harsh environments.

The filters can be replaced easily without any tools and without disconnecting the heated sample line.

TECHNICAL DATA

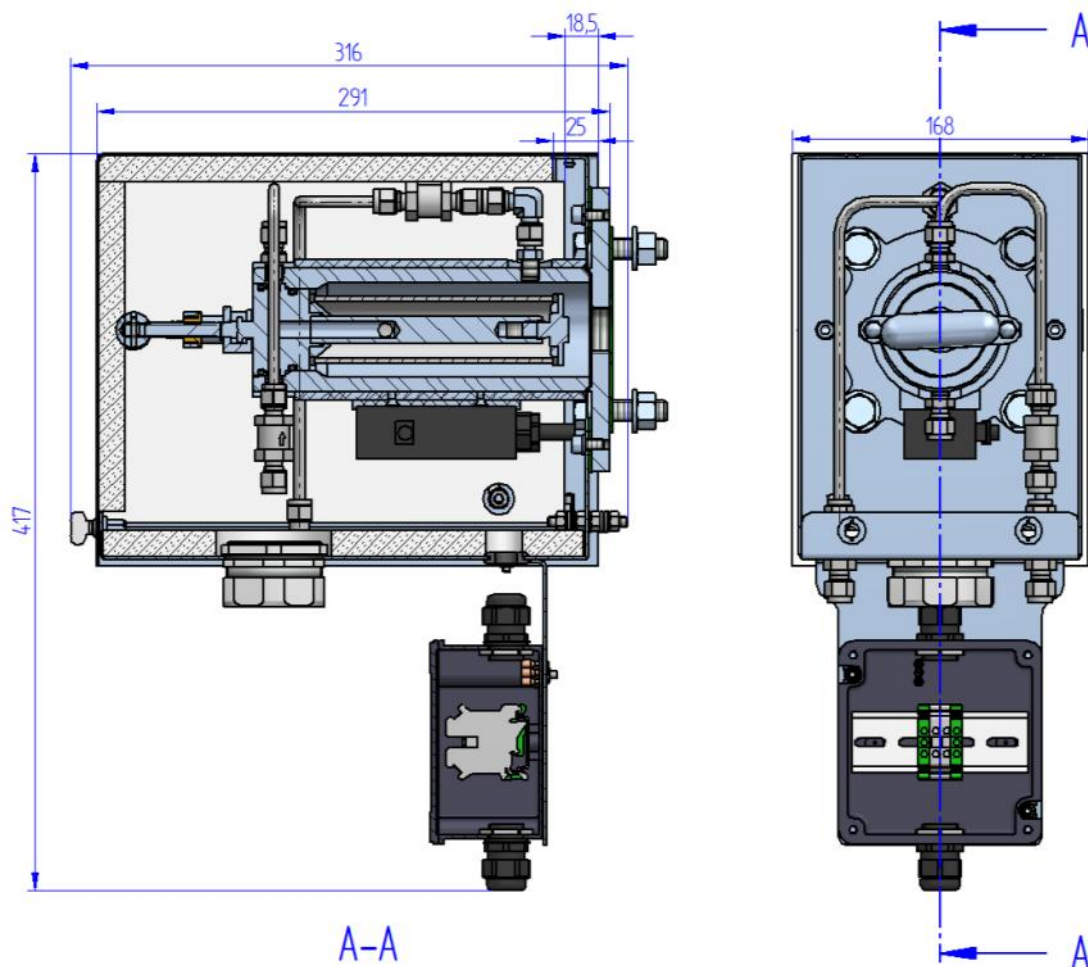

SPECIFICATIONS	
Filter element Option	SiC; pore size 2µm; 40/20x135 mm surface coated 0,2µm
Operating pressure Option	max. 200 kPa abs. max. 700 kPa abs.
Flow rate	up to 600Nl/h
Mounting flange Option	DN 65, PN6; DIN 2573; SS316Ti 2" ANSI-flange, 150lb.
Mounting angle	recommended 5°-15° incline to allow condensate drainage
Sample gas inlet	G3/4" female thread
Sample gas outlet	1/8" NPT female thread
Test gas port	6mm SS316 bulkhead union
Back purge port	6mm SS316 bulkhead union
Gas wetted parts	1.4571, SiC, Viton® (FKM)
Factory setting	120°C @ 20°C
Permissible ambient temperature	0°C ... +40°C
Weight	Approx. 11 kg
Housing	SS316 stainless steel

SPECIFICATIONS (for self limiting versions)	
Power consumption	Approx. 80 Watt
Heater element	PTC self limiting
Dual power supply	115VAC to 230VAC 50/60 Hz
Electrical connection	Clamps max. 2,5 mm ²
Protection class	Heater: IP 68 Probe: IP 43 Junction box: IP66/67
Type of protection	Heater: II 2 G Ex d IIC T3 / II 2 D Ex tD A21 IP65 T135°C Junction box: II 2 G Ex em II T6/T5/T4 II 2 D Ex tD A21 IP66 T80°C, T95°C
Approval / Sign	CE Heater: PTB 02 ATEX 1116 X IECEX PTB 07.0055X Junction box: PTB 99 ATEX 3103 LCIE 02 ATEX 6240 IECEX PTB 06.0026

ORDER CODE

Gas sampling probes

	Filter			Options / Equipment					Flange		Voltage		Ex Zone	
	heated	2µm SiC	0,2µm surface coated	Backpurge Port *1	Calibration Port *1	Temperature Controller	self-limited	Weather protection	DN65/PN6	2" ANSI	230VAC 50/60Hz	115VAC 50/60Hz	Ex Zone 1	Ex Zone 2
35.00400 JES301E1S	X*3	X					X	X	X		X	X	X	
35.00402 JES301E1SB	X*3		X	X			X	X	X		X	X	X	
35.00404 JES301E1SC	X*3	X			X		X	X	X		X	X	X	
35.00406 JES301E1SBC	X*3		X	X	X		X	X	X		X	X	X	
35.00408 JES301E1SD	X*3	X			X*2		X	X	X		X	X	X	
35.00410 JES301E1SBD	X*3		X	X	X*2		X	X	X		X	X	X	

*1 ...with non return valve
 *2 ...heated calibration port
 *3 ...heated up to 120°C

Sampling pipe max. 600°C		Material	Length
35.00060	ER-S10	SS316Ti (1.4571)	1000 mm
35.00061	ER-S15	SS316Ti (1.4571)	1500 mm
35.00062	ER-S20	SS316Ti (1.4571)	2000 mm
35.00063	ER-S25	SS316Ti (1.4571)	2500 mm
35.00065	ER-S30	SS316Ti (1.4571)	3000 mm

Sampling pipe max. 140°C		Material	Length
35.00080	ER-T10	Teflon® (PTFE)	1000 mm
35.00081	ER-T15	Teflon® (PTFE)	1500 mm
35.00082	ER-T05	Teflon® (PTFE)	500 mm

Sampling pipe max. 1200°C		Material	Length
35.00050	ER-K10	Kanthal	1000 mm
35.00051	ER-K15	Kanthal	1500 mm
35.00052	ER-K20	Kanthal	2000 mm

Sampling pipe max. 1100°C		Material	Length
35.00070	ER-H10	SS314 (1.4841)	1000 mm
35.00071	ER-H15	SS314 (1.4841)	1500 mm

Accessories for back purge version

35.00110	JES301KE1	Back purge valve box 230VAC
35.00111	JES301KE1	Back purge valve box 24VDC

bold...Standard configuration

ORDER CODE

In-Situ pre filter

In-Situ pre filter, pore size 3 µm, SS 1.4404, max. 550°C, diameter 50 mm		
35.00703	HD-03	Length 300 mm, up to 10 g/m ³
35.00705	HD-05	Length 500 mm, up to 20 g/m ³
35.00710	HD-10	Length 1000 mm, up to 15 g/m ³
In-Situ pre filter with V-deflector, pore size 3 µm, SS 1.4404, max. 550°C, diameter 50 mm		
35.00803	HD-03V	Length 300 mm, up to 10 g/m ³
35.00805	HD-05V	Length 500 mm, up to 20 g/m ³
35.00810	HD-10V	Length 1000 mm, up to 15 g/m ³

Extension tube for In-Situ pre filter	Material	Length
35.00910	HD-ET10	SS316 (1.4401) 1000 mm
35.00920	HD-ET20	SS316 (1.4401) 2000 mm
35.00925	HD-ET25	SS316 (1.4401) 2500 mm
Extension tube for In-Situ pre filter	Material	Length
35.00926	HD-ETK25	Kanthal 2500 mm

Consumable parts and flange adaptors

Consumable parts	
35.90010	O-ring A, 200°C, Viton® (FKM)
35.90011	O-ring B, 200°C, Viton® (FKM)
35.90012	O-ring A, 315°C, Kalrez® (FFKM)
35.90013	O-ring B, 315°C, Kalrez® (FFKM)

Flange adapter	Material	Dimensions
35.08010	SS304 (1.4301)	DN65/PN6 to 2 1/2"
35.08030	SS304 (1.4301)	DN65/PN6 to DN80/PN6
35.08020	SS304 (1.4301)	DN65/PN6 to 3"
35.08040	SS316Ti (1.4571)	DN65/PN6 to DN100/PN25
35.01401	Thermal spacer	

Spare parts

Spare parts	
35.90014	Filter element SiC F10, 2 µ, 40/20 x 135mm
35.90015	Gasket for filter element, 200°C, Viton® (FKM)
35.90016	Gasket for filter element, 315°C, Kalrez® (FFKM)
35.90100	Spare part kit, consisting of 1 x O-ring A and B, 1 x filter element SiC F10, 2 x gaskets Viton®
35.90101	Spare part kit, consisting of 1 x O-ring A and B, 1 x surface coated filter element, 2 x gaskets Viton®
35.90018	Surface coated filter element, 40/20x135mm
K9518101	PTC heater element 115-230VAC
35.90080	Male connector SS316, for 6 mm tube
35.90081	Male connector SS316, for 8 mm tube

Spare parts	
35.90082	Blind plug, SS316
35.90083	Male connector, SS316, for 1/4" tube
35.90084	Male connector, SS316, for 3/8" tube
35.90085	Elbow connector, SS316, for 6 mm tube
35.90086	Male connector, SS316, for 6 mm tube
35.90087	Adapter for G3/8" connector SS316, for 10 mm tube
K3522001	Non return valve
K9507401	Junction box
35.90070	T-handle assembly kit
35.90071	Extractor kit complete

Gasket for flange	
35.00955	Flange gasket DN65

Gasket for extension tube		
35.00950	HD-ETGK	3/4", 27x38,2, SIL C 4400

bold...Standard configuration

Specification subject to change without notice.

PDS_E_JES301_EEx_v1.3

JCT Analysentechnik GmbH

Werner Heisenberg-Straße 4 A-2700 Wiener Neustadt
 Tel. +43 (0) 2622 / 87201 Fax +43 (0) 2622 / 872011
 E-Mail: sales@jct.at Web: www.jct.at

