

- Sampling Conditioning Systems
- Process Analytics
- System Integration
- Gas Generators
- FTIR-Analyser

gas analysers

# HYDROCARBON ANALYSER

## Thermo-FID FE



### FEATURES

- ◆ For use in hazardous area zone 1 or 2
- ◆ Automatic start up
- ◆ Automatic calibration
- ◆ Automatic flame ignition
- ◆ Automatic flue shut off
- ◆ Built-in catalyst for burner air
- ◆ Easy to use
- ◆ TÜV and MCERTS approved

The Model Thermo-FID FE is a microprocessor based high temperature flame ionisation detector (FID) that continuously measures total hydrocarbons (THC) concentration under a wide variety of different process conditions. The FE uses an unique FID sensor design which allows an accurate and linear response due to precisely controlled mass flow conditions of sample gas and support gases such as hydrogen and burner air. The sample gas passes through a heated detector containing a hydrogen flame which burns and ionises the hydrocarbons. An electrometer measures the resulting current flow. The ionisation current will be amplified and displayed either in ppm, mg/m<sup>3</sup>, g/m<sup>3</sup>, Vol. % or % LEL.

The instrument is approved according TÜV 17. BImSchV, MCERTS and is compliant to EN 14181. The Thermo-FID model FE introduces the standard instrument configuration built into an rated IP45 or into an optionally offered IP65 field enclosure perfectly suited to fulfil industrial field installation requirements. All gas fittings, signals and main power connections are located at the bottom of the instrument enclosure of the FE.

The sensor and pneumatic assembly are fully heated up to 200°C to avoid any condensation. The sensor features a heated pump without moving parts for superior efficiency and long life time. A customer supplied instrument air drives the integrated air driven sampling system. The sampling method is effective and requires very low maintenance. The FE is almost independent of pressure fluctuation from the process stream in the range from approximately 800 to 1600 mbar absolute.

A sophisticated built in microprocessor controls the analyser, offers full diagnostic capabilities, fully automatic calibration, automatic start up even after a power supply fail, automatic flame ignition, automatic fuel shut off system, remote service diagnostic and many ideal features for unmanned plant and safety system operation. This includes alarm relays for error, maintenance request and status. The sensor features high performance, very low maintenance and a long life time. The FE version is available for hazardous area either in zone 1 or zone 2 as an option.

# Thermo-FID FE - General Information

## GENERAL FEATURES

The Thermo-FID is used in a variety of industrial applications, environmental measurement systems and R&D projects. Typical use of the Thermo-FID are LEL control, flue/exhaust gas at waste incinerators or the petro/chem-industry, ambient air analysis, work place control MAK/TRK-limits and process control optimisation.

The microprocessor controlled Thermo-FID provides menu driven 'clear text' user friendly interface information on an alphanumeric display. All operational and self diagnostic data are also available on RS232 and/or analog/digital outputs (status alarm PCB, optional). Additional application oriented functions can be integrated or/and added to the standard analyser. A fully automated and continuous self diagnostic and log book entries for all operation and calibration data guarantees an optimum analyser up time. The unique close couple detector design (no cables, etc.) provides a low drift operation and a wide dynamic range with always optimum signal noise ratio.

All digital input features are designed according NAMUR guidelines, all digital outputs are potential free contacts.

Analog output signals are offered as standard 1 x 0/4-20 mA, 600 Ohm load (not galvanic isolated), optional 4 x 0/4-20 mA optical galvanic isolation available on the status & alarm card. Instrument operation and configuration by remote control is also available on 2 x RS232.

## FLOW CHART

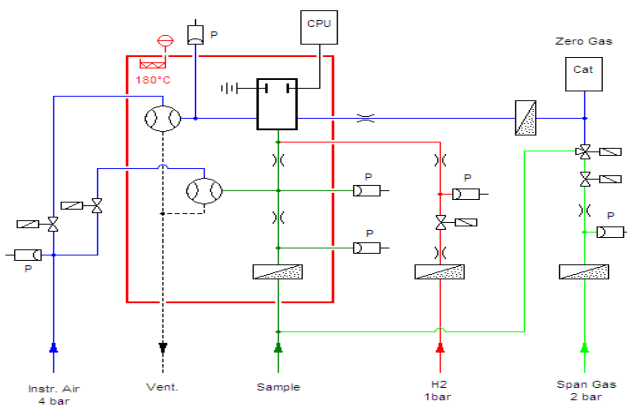

## PRINCIPLE OF OPERATION

The measurement principle of the Thermo-FID is based on the ionization of hydrocarbons in a hydrogen flame.

Since the pure hydrogen flame creates only a very small basic the burning of hydrocarbons results in an ionisation current being decades higher than one created by the pure hydrogen flame.

Thus an exceptional constant sample gas flow and a constant hydrogen stream are drawn to the burner nozzle which being on a negative potential (approx. - 80 to - 400 VDC) measured by the close coupled detector. In the temperature controlled burning chamber, the mixture is burned by adding hydrocarbon free air in relation of approx. 10 : 1.

The resulting ions are collected on a polarized electrode, amplified and put to display. Best measurement performance is provided by offering a very constant sample mass flow and pressure conditions to the chamber. Due to the optimum design of the instrument, pressure variation at the sample point are allowed between 800 mbar abs. up to 1600 mbar abs. without lack of performance.

The Thermo-FID features two separate microprocessor controlled pressure compensations in order to avoid any influence from environmental or sample conditions to the measurement.

Instead of using conventional heated sample pumps, instrument air driven heated ejector pumps (except portable version) are used providing trouble free, maintenance free and exceptional stable sample flow conditions. Very fast response time is achieved by an optimum sample loop and minimum dead volume design. The sample flow can be set between 2 and 90 NI/hr depending on customers response time expectation or/and application needs (i.e. LEL, flue gas conditions etc.). The standard sample flow is between 10 and 25 NI/hr.

The Thermo-FID is equipped with a flame trap also used as a heated sample inlet filter. All material in contact with the sample gas as well as the measuring chamber are heated between 120°C and 200°C in order to avoid any kind of condensation or/and corrosion.

# Thermo-FID FE - Accessories

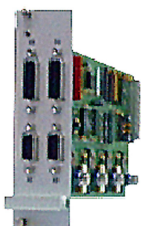

## STATUS BOARD

- Status signals all isolated, potential free
- 4 0/4 ... 20 mA isolated outputs
  - 4 isolated alarm relays
  - 2 analogue inputs to control gas supply
  - 2 digital outputs 24 V DC/0.5 A
  - 2 digital inputs free selectable
  - 1 digital output 24 V = /0.5 A, controlled via timer for automatic back purge of sample filter

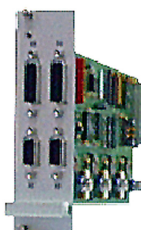

## CONTROL BOARD FOR SAMPLE POINT SCANNER (MAX. 2 CARDS)

- 8 digital outputs 24V=0.5A to control solenoid valves
- 8 isolated alarm relays
- 8 digital inputs for external sample point scanning

- Optional
- 8 0/4...20mA isolated outputs, load max. 600W

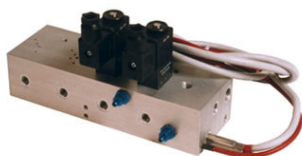

## MSU-HT

- High temperature sample point scanner heated up to 180°C.  
4/8 sample point scanner, self sucking with bypass pump, each individual gas stream comes with flow alarm device.  
Optional integrated dilution device available.

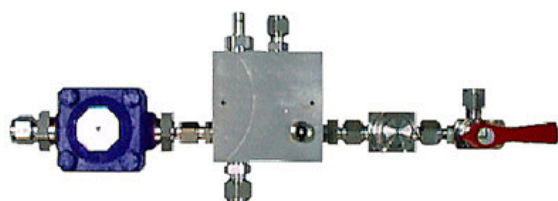

## EXPANSION DEVICE FOR STEAM

- To determine organic C in steam at 2...15bar heated up to 180°C. Additional multi-point scanner to determine organic C is available. Inlet shut-off valve, inlet filter, heated manifold and condenser are in scope of delivery.



## INLINE-STRIPPER

- To determine volatile organic C (VOC) in waste water and cooling water towers.

## TECHNICAL DATA

### SPECIFICATIONS

Range	0 ... 1 ppm / 0 ... 100.000 ppm
Resolution	< 10 ppb in smallest range
Linearity	Within +/- 1 % of full scale
Selectable units	ppm, mg/m <sup>3</sup> , Vol%, %LEL
Repeatability	Within 1 % of full scale reading
Linearity	Within 1 % of full scale reading
Response time	< 1 sec at sample gas inlet
Flow rate	2, 5, 25 or 90 l/h @ 1013 mbar
Sample pressure	800 ... 1600 mbar absolute
Cell temperature	Adjustable up to 200 °C
Flame ignition	Automatic after warm up
Safety	Flame out alarm and fuel shut off
Alarm function	Free adjustable alarms
Analog output	4-20 mA, max. 600 Ω load, non isolated

### SPECIFICATIONS

Digital outputs	RS232C, 422 (optional), printer
Fuel requirements	UHP H <sub>2</sub> , @ 1 barg. 40 cc/min
Compressed air	4 barg instrument grade; -30 °C PDP
Air consumption	2 Nm <sup>3</sup> /h @ 4 barg
Span gas	Known concentration @ 2 barg
Burner air	Built in, made via internal catalyst
Zero gas	Built in, made via internal catalyst
Warm up time	< 30 minutes
Ambient temp.	- 5 ... +40 °C (others on request)
Approvals	TÜV, MCERTS and LEL approved
Protection class	IP45; IP65 optional
Power supply	115 or 230 V/50 or 60 Hz, 250 VA
Dimensions	440 x 450 x 400 mm (W x H x D)
Weight	27 - 29 kg

### APPLICATION

Emission monitoring for stack gas,  
 Scrubber efficiency,  
 Vehicle emission,  
 Process gas analysis,  
 Leak detection,  
 Solvent recovery,  
 Painting streets,  
 HC Monitoring in steam  
 Monitoring volatile organic,  
 Abatement equipment,  
 Fugitive emission monitoring,  
 Carbon absorbers,  
 Safety monitoring LEL,  
 Coating process control,  
 Monitoring of traces in cooling tower

### FEATURES & BENEFITS

Automatic start up / ignition  
 Built in zero gas  
 Built in burner air  
 Microprocessor controlled sample gas flow  
 Integrated flame arrestor Ex sIIC  
 Heated sampling pipe  
 No moving sample pump ejector  
 Microprocessor controlled driving voltage  
 Automated adjustment of flow  
 Automatic fuel shut off system  
 Independent of sample pressure fluctuation  
 Unique sample flow control  
 Multi point sampling (optional)  
 Remote control and remote service (optional)  
 Automatic ranging (optional)

### ACCESSORIES

Hydrogen generator to reduce bottles  
 Suitable for use for hazardous area zone 1 or 2, ATEX  
 Alarm and Status Board, 4 x 4-20 mA isolated output  
 Inline stripper for VOC monitoring  
 Expansion device for steam  
 Heated sample multi point scanner

Specification subject to change without notice.

PDS\_E\_FID-FE\_11/06\_Rev. 0

## JCT Analystechnik GmbH

Werner Heisenberg-Straße 4 A-2700 Wiener Neustadt  
 Tel. +43 (0) 2622 / 87201 Fax +43 (0) 2622 / 872011  
 E-Mail: [sales@jct.at](mailto:sales@jct.at) Web: [www.jct.at](http://www.jct.at)

