

CROSS STACK LASER GAS ANALYZER

(Single beam version)

DATA SHEET
ZSS-S

Cross stack laser gas analyzer (ZSS) provides continuous measurement of density of HCl contained in flue gas in waste incineration plant and industrial waste disposal facility, NH₃ in power plant and denitration equipment, CO, CO₂, and O₂ in iron and steel plant and chemical plant with high speed response. Since ZSS is installed directly on the flue(pipe) where objective gas flow to be measured, preparation is not required for measured gas to be introduced to the analyzer, which is required for sampling method. This analyzer can be used under high dust conditions, so it is possible to install upstream of the bagfilter where gas sampling is normally difficult. This is the first laser gas analyzer for environment and process in Japan produced by Fuji.

FEATURES

1. Maintenance free thanks to using the long-term stable parts.
2. Running cost is minimized by no need of gas sampling devices and having few parts to replace.
3. Long and high stability due to almost no drift.
4. Since adopting the near-infrared semiconductor laser which emit light of the wavelength of measured component, hardly affected by interference of other gas.
5. It is suitable for injection control of slaked lime, measur-



- ing the residual ammonia gas and monitoring and control of converter furnace of combustible gas recovery due to high-speed response for 1 to 5 seconds.(high-speed response type: 1 to 2 seconds)
6. It is measurable at high temperature and dust circumstance. In addition performance of dust resistance has been improved.
7. It is environment-friendly product. Because power consumption is 75VA or lower when 100V AC.

SPECIFICATIONS

Measurable component and range:

Measurable Component	Component	Min.measuring range Note 1)	Max.measuring range Note 1)	Measured gas temperature	Purge gas	4th digit
1-component analyzer	HCl	10 ppm	5000 ppm	400°C or less	Air	C
	NH ₃	15 ppm	5000 ppm	450°C or less		W
	CO	2.0 vol%	50 vol%	300°C or less		A
	CO (High temperature)	10 vol%	50 vol%	1200°C or less		B
	CO ₂	2.0 vol%	50 vol%	300°C or less		G
	CO ₂ (High temperature)	10 vol%	50 vol%	1200°C or less		H
	CH ₄	100 ppm	50 vol%	300°C or less	R	
	O ₂	4 vol%	100 vol%	300°C or less	N ₂	P
	O ₂ (High temperature)	4 vol%	50 vol%	1200°C or less		Q
	O ₂ (Air purge)	25 vol%	100 vol%	400 to 1200°C	Air	T
2-component analyzer	HCl+H ₂ O (50 vol%)	Note 2) 50 ppm (HCl)	1000 ppm (HCl)	130 to 400°C	Air	F
	NH ₃ +H ₂ O (50 vol%)	Note 2) 50 ppm (NH ₃)	1000 ppm (NH ₃)	130 to 450°C		X
	CO+CO ₂	2.5 vol%	50 vol%	300°C or less		K
	CO+CO ₂ (High temperature)	10 vol%	50 vol%	1200°C or less		L

Note 1) Min. and Max. measuring range in the above table are for measuring path length (stack length) of 1m. See below on the ranges for other path lengths.

Note 2) Consult us when selecting H₂O analyzer.

• Calculation method of measuring range for optical path length other than 1m

Measuring range = [Min. or Max. range ÷ path length in Table 1]

Ex. 1) HCl analyzer, path length 5m
 Max. range: 5,000ppm ÷ 5m = 1,000ppm
 Min. range: 10ppm ÷ 5m = 2ppm
 Therefore, measuring range is between 0 to 2 ...1,000ppm

Ex. 2) HCl analyzer, path length 0.5m
 Max. range: 5,000ppm ÷ 0.5m = 10,000ppm
 Min. range: 10ppm ÷ 0.5m = 20ppm
 Therefore, measuring range is between 0 to 20 ...10,000ppm

Measurement principle:

Non-dispersive infrared absorbance system (NDIR)

Measuring method:

Cross-stack system (path system)

Use application:

Waste incineration plant, industrial waste disposal facility, power plant iron and steel plant, paper plant, pulp mill, chemical plant and biopant etc...

Light source:

Near-infrared laser

Laser class:

Class 1 (High temperature version and instrument air purge version fall under CLASS 3B)

Dimensions:

Refer to outline diagram

Mass:

Receiver/Transmitter unit: Approx. 10kg

Control unit: Approx. 8kg

Structure:

Outdoor use type, dustproofing/rainproofing structure (IP65)

Box finish color:

Receiver/Transmitter box: gray

Control unit cover: blue

Control unit case: silver

Material:

Receiver unit / Transmitter unit: Aluminum, SUS316

Control unit: Aluminum

Materials of gas-contacting parts:

SUS316, BK7, FKM, PTFE, glass-cloth, silicone

Air purge connection diameter:

RC1/4 (tube $\varnothing 10 \times 8$)

Power supply:

Rated voltage 100 to 240V AC

(Operating voltage: 90 to 264 V AC)

Rated frequency 50/60 Hz

Power consumption:

Max. rated power: Approx. 75VA or less

Calibration interval:

Once every six months (Maintenance cycle may vary with conditions and environment of use.)

Indicator (control unit):

LCD with back light

Communication functions:

RS-485(Modbus[®] protocol)

Cable length:

Receiver unit to Transmitter unit: Standard 2m (Maximum 25m)

Receiver unit to control unit: Standard 5m (Maximum 100m)

Analog output:Non-insulation, 2 or 4 points

4 to 20mA DC or 0 to 1V DC

(1 to 5V DC, 0 to 5V or 0 to 10V is available.)

Allowable load: 4 to 20mA DC 550 Ω or less, 0 to 1V DC 100k Ω or more

(Output measurement value and O₂ corresponding value. Average value and instantaneous value are switchable by the settings.)

Analog input:2 or 6 points

4 to 20mA DC

Measured gas pressure, measured gas temperature, measured gas velocity, O₂ gas concentration, water concentration, air purge pressure

(Measurement concentration correction, O₂ correction or alarm output is performed according to the input signal.)

Contact output: 5 points

Relay contact output (contact capacity: 24 V DC, 1A)

1a contact output: low light transmission, outside the range of upper/lower limits, device failure, during hold/during calibration

1b contact output: power supply off

Contact input (option): 3 points

Photo coupler receiver contact input (operating voltage 12 to 24V DC / 5 to 20mA)

Average value reset signal, switching instantaneous value/moving average value and remote hold

Alarm output (screen-displayed):

LD failure, LD temperature error, high gas temperature, air purge (low pressure), box temperature warning, low light transmission, PD over range, connection error, AI under, Range (H-Limit) or Range (L-Limit)

Display contents:

Component, concentration (instantaneous value, average value O₂ correction instantaneous value and O₂ correction average value), alarm (fault status)

CONTACT OUTPUT CONTENTS

Low light transmission (1a contact):

Contact output is performed (close) when the amount of light transmission is insufficient.

Outside the range of upper/lower limits (1a contact):

According to the preset upper or lower limit alarm value, contact output is performed (close) when it becomes lower than alarm upper/lower limit.

Device failure (1a contact):

Contact output is performed (close) when laser failure, laser temperature control failure, exceeding the amount of light transmission or communication error are occurred.

During hold/during calibration (1a contact):

While AO output is held by the hold setting, the values, output (close) of which is held, is the ones just before the holding or arbitrary set values.

Output (close) during calibration

Power supply off (1b contact):

Output (close) while power supply is off

CONTACT INPUT CONTENTS (OPTION)

Average value reset signal:

Output of converted average value is started from the initial state by applying rectangular-wave voltage (pulse width 2 sec or more) to the input terminal of average value resetting. Output is reset by inputting and restarted by opening.

Switching instantaneous value/moving average value:

Switching to and from the instantaneous value and the average value of the analog output is performed by applying rectangular-wave voltage (pulse width 2 sec or more) to the input terminal for switching between the instantaneous value and the moving average values.

Remote hold:

The analog output is held by applying rectangular-wave voltage (pulse width 2 sec or more) to the remote hold input terminal, and restarted by applying it again.

FUNCTIONS

O₂ correction:

Conversion of measured HCl, NH₃ and CO gas concentrations into values at standard O₂ concentration

Correction formula:

$$C = \frac{21 - O_n}{21 - O_s} \times C_s$$

C: Converted concentration

C_s: Measured concentration of sample gas

O_s: Measured O₂ concentration (Upper limit settable 1 to 20% O₂)

O_n: Standard O₂ concentration (value changeable by setting; 0 to 19% O₂)

The result of calculation is indicated and output in an analog output signal.

INSTALLATION ENVIRONMENT

Ambient temperature:

-20 to 55°C (Receiver unit/Transmitter unit), -5 to 45°C (control unit)

Ambient humidity:

90% R.H. or less

Measurable optical path length (inner diameter of stack):

0.5 to 10m

Standard flange:

JIS10K 50A flange (JIS B 2212)

Purge:

Instrument air (compressor must be installed when power supply cannot be provided. Does not contain oil and mist). Use N₂ gas except for air purge version. Pressure 0.5MPa or more depending on measured gas velocity.

Purge flow rate:

20L/min or more (depending on measured gas temperature, velocity, pressure, moisture and dust)
One-side air purge flow rate: (L/min) = Gas flow rate (m/s) × 10 (in case of 50A pipe)

Measured gas condition:

Temperature: Refer to page 1.

Pressure:

±10kPa (O₂ for combustion control is -10kPa to 100kPa)

Moisture:

50vol% or less (no condensation)

Velocity:

Range of purge flow rate (gas flow rate (m/s) = one side flow rate (L/min) / 10)

Note) When measuring high-temperature gas at 500°C or higher, install a pressure sensor on the air-purge unit to monitor air purge. If measurement is taken while purge is not performed, the device may be damaged.

Dust (Enhanced dust resistance is available):

Dust resistance depends on conditions such as measuring component, equipment specification, optical path length, and particle diameter. Consult us for use in a dusty environment.

Vibration:

0.5G or less (0.2G or less when the frequency range is 20 to 40Hz) (when optical path length is 1m)

Mounting angle:

Horizontally ±5 degrees or less (No dew condensation should accumulate on the window.)(Refer to page 11.)

PERFORMANCE (EXCEPT FOR H₂O)

Repeatability:

±1.0%FS (depending on measuring component and measuring range)

Linearity:

±1.0%FS (depending on measuring component and measuring range)

Zero drift:

±2.0% FS (depending on measuring component and measuring range)

Interference from other gas components:

±2.0%FS (The gasses which have no absorption within the wavelength range of measured gas (several tens pm) do not interfere in principle).

Minimum detectable limit:

1% of minimum detectable limit

Response time (90% FS response):

1 to 5 seconds (high-speed type: approx.1 to 2seconds)

Warm up time:

90 minutes or less

* Excluding influenced range with absorptive gases such as HCl and NH₃

* H₂O measurement is a function to detect the presence of moisture and its change. The accuracy is not guaranteed by this function.

EC DIRECTIVE COMPLIANCE

Low voltage safety:

EN61010-1(2010)

EN62311(2008)

EN60825-1: 1993, A1: 1997, A2: 2001

Electromagnetic:

"Installation Category II"

Compatibility

EN61326-1(2006)

EN61326-2-3(2006)

EN61000-3-2(2006), A1(2009), A2(2009)

EN6100-3-3(2008)

Measuring category:

II(CAT II)

LIST FOR COMBINATIONS OF MEASURABLE COMPONENTS, UNITS AND MEASUREMENT RANGES

Component	Measuring range	
CO	0 ~ 2, 2.5, 4, 5, 10, 15, 20, 25, 50 vol%	
CO (For use in high temp.)	0 ~ 10, 15, 20, 25, 50 vol%	
HCl	0 ~ 10, 15, 20, 25, 50, 100, 200, 250, 400, 500, 1000, 2000, 5000 ppm or mg/m ³	
CO ₂	0 ~ 2, 2.5, 4, 5, 10, 15, 20, 25, 50 vol%	
CO ₂ (For use in high temp.)	0 ~ 10, 15, 20, 25, 50 vol%	
O ₂	0 ~ 4, 5, 10, 15, 20, 25, 50, 100 vol%	
O ₂ (For use in high temp.)	0 ~ 4, 5, 10, 15, 20, 25, 50 vol%	
O ₂ (For use air purge)	0 ~ 25, 50, 100 vol%	
CH ₄	0 ~ 100, 200, 250, 400, 500, 1000, 2000, 5000 ppm or mg/m ³ 0 ~ 2, 2.5, 4, 5, 10, 15, 20, 25, 50 vol%	
NH ₃	0 ~ 15, 20, 25, 50, 100, 200, 250, 400, 500, 1000, 2000, 5000 ppm or mg/m ³	
CO+CO ₂	1st comp.: CO	0 ~ 2.5, 4, 5, 10, 15, 20, 25, 50 vol%
	2nd comp.: CO ₂	0 ~ 2.5, 4, 5, 10, 15, 20, 25, 50 vol%
CO+CO ₂ (For use in high temp.)	1st comp.: CO	0 ~ 10, 15, 20, 25, 50 vol%
	2nd comp.: CO ₂	0 ~ 10, 15, 20, 25, 50 vol%

BASIC PRINCIPLE

Near-infrared semiconductor laser is adopted for the light source and photo-diode is adopted for photo-detection. Each measured gas component has its own wavelength range where the gas absorbs the light (see the figure below).

The wavelength range consists of a set of many absorption lines, and one of these lines is used for measurement.

As measurement is performed in this very narrow wavelength range, no other gas does not have an interference in principle.

To detect the gas concentration, used is not a variation of light intensity, but intensity of modulated signal amplitude.

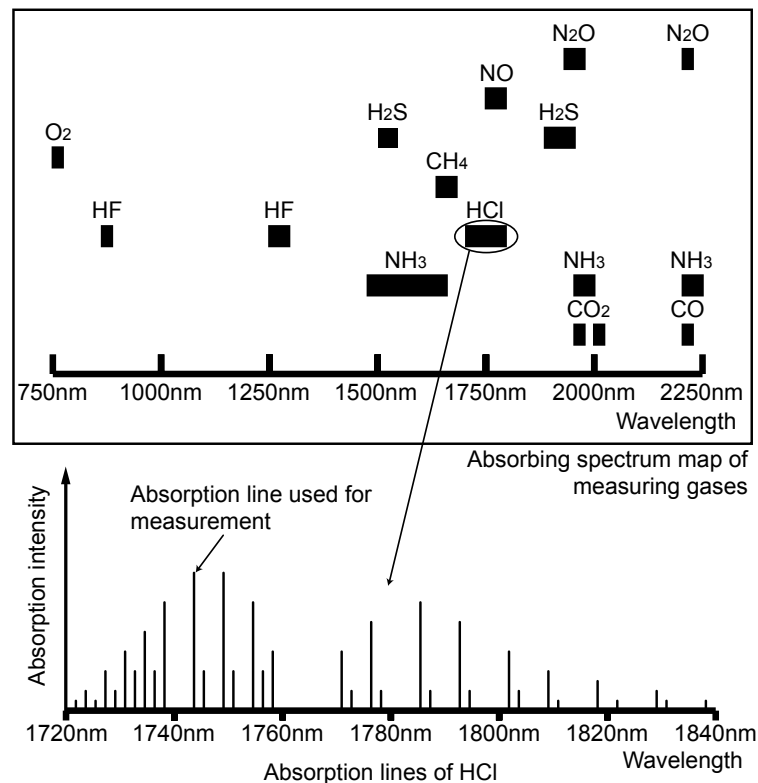

CALIBRATION/INSTALLATION FIXTURES LIST (OPTION)

	Parts name	Quantity	Type
(1)	Cable between receiver unit and control unit (for calibration)	1	ZZP*ZSSTK4J1271C2
(2)	Cable between receiver unit and transmitter unit (for calibration)	1	ZZP*ZSSTK4J0641C3
(3)	Calibration gas cell (*3) (HCl, NH ₃ , CO, CO ₂ , CO+CO ₂ , CH ₄)	1	ZZP*ZSSTK4J3676C1
	Calibration gas cell (*3) (HCl+H ₂ O, NH ₃ +H ₂ O, O ₂)		ZZP*ZSSTK4J5026C1
(4)	Optical axis adjusting tool (laser pointer, target)	1	ZZP*ZSSTK4J1274C1
(5)	IR card (for NH ₃)	1	ZZP*ZSSTK7N4505P1
(6)	Check cell	1	ZZP*ZSSTK4J2605C1
(7)	Filter regulator	1	ZZP*ZSSTK7N7466P1
(8)	Mist separator	1	ZZP*ZSSTK7H8049P1
(9)	R1/4 stopper (plug) for mist separator	1	ZZP*ZSSTK738114P7
(10)	Flow meter (20 to 100L/min) (*4)	1	ZZP*ZSSTK7N4624P1
	Flow meter (4 to 50L/min) (*4)	1	ZZP*ZSSTK7N4624P2
	Flow meter (30 to 300L/min) (*4)	1	ZZP*ZSSTK7N8849P1
(11)	Air-set box (20 to 100L/min)	1	ZZP*ZSSTK7N6685C1
	Air-set box (4 to 50L/min)	1	ZZP*ZSSTK7N6685C2
	Air-set box (30 to 300L/min)	1	ZZP*ZSSTK7N6685C3
(12)	Air purge mechanism (20 to 100L/min)	1	ZZP*ZSSTK7P1433C1
	Air purge mechanism (4 to 50L/min)	1	ZZP*ZSSTK7P1433C2
	Air purge mechanism (30 to 300L/min)	1	ZZP*ZSSTK7P1433C3
(13)	BNC cable for optical axis adjustment	1	ZZP*ZSSTK7P2524C1

- * 3: Standard length 1m (250mm or 500mm when the measuring range is low concentration)
- * 4: Usually, 2 units are required to adjust each air purge for receiver unit and transmitter unit.

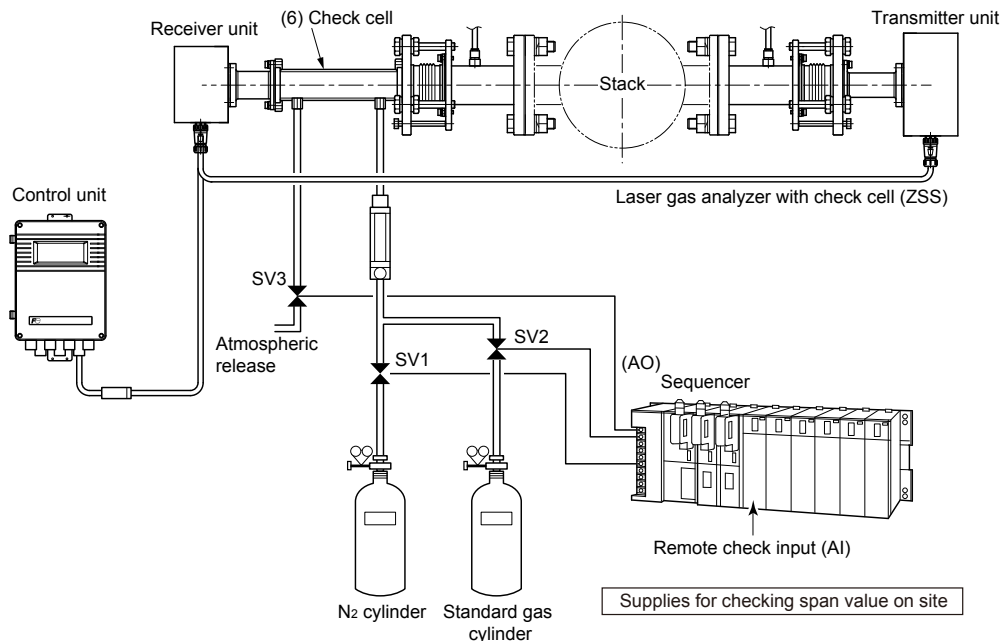
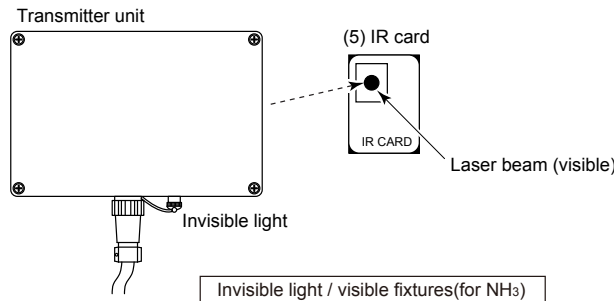
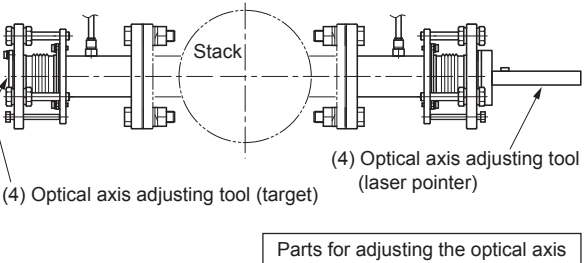
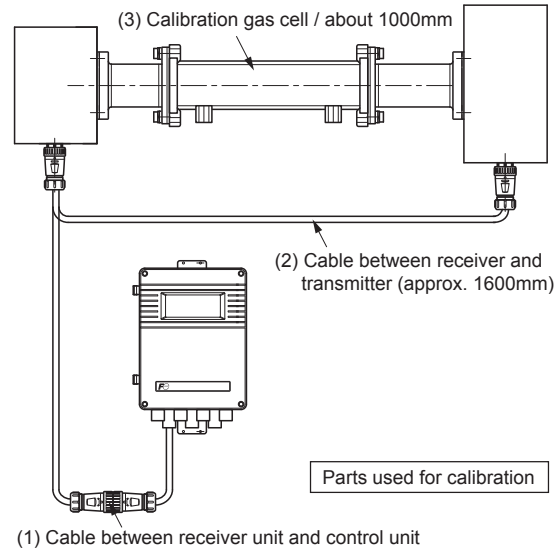

(11) Air set box

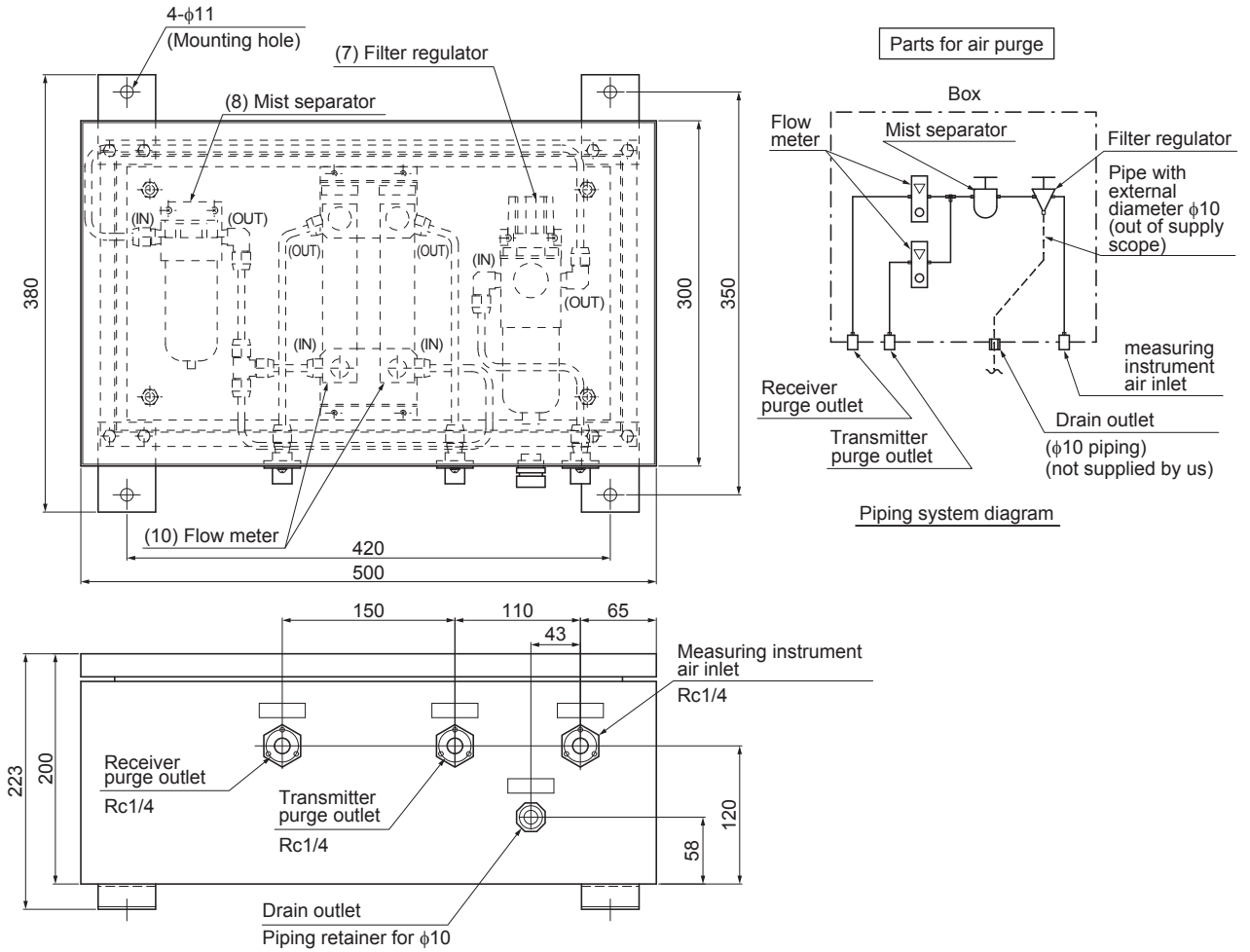

(12) Air purge mechanical part

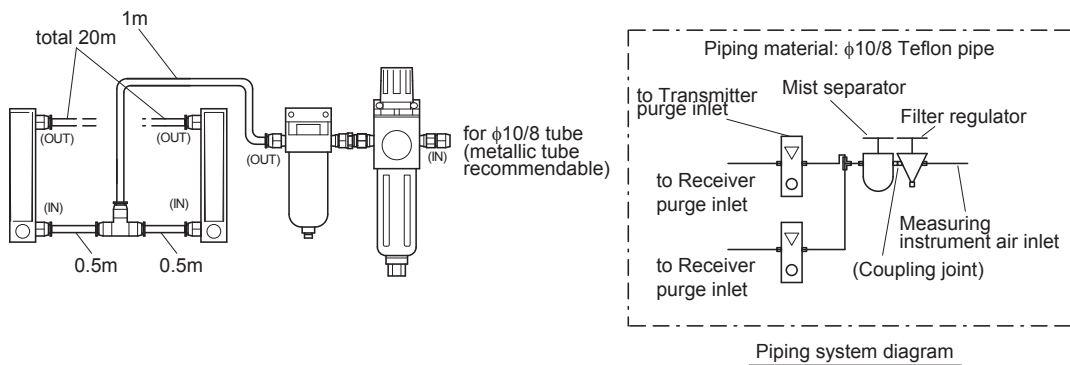

(13) BNC cable for optical axis adjustment

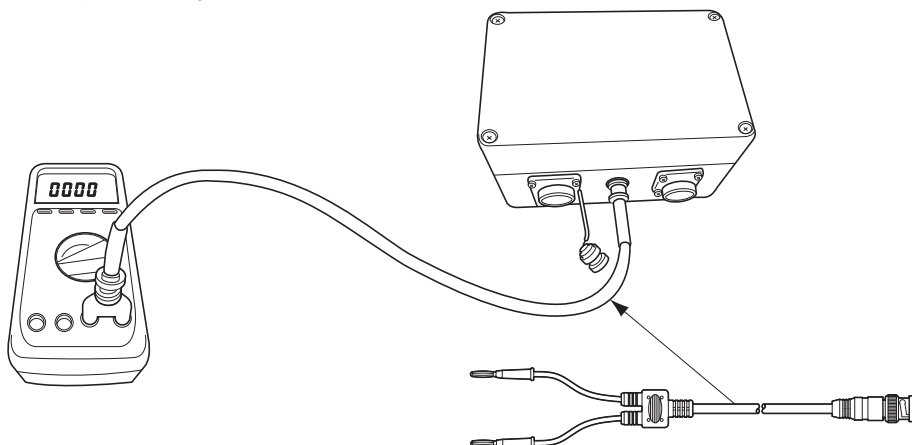

OUTLINE DIAGRAM (Unit : mm)

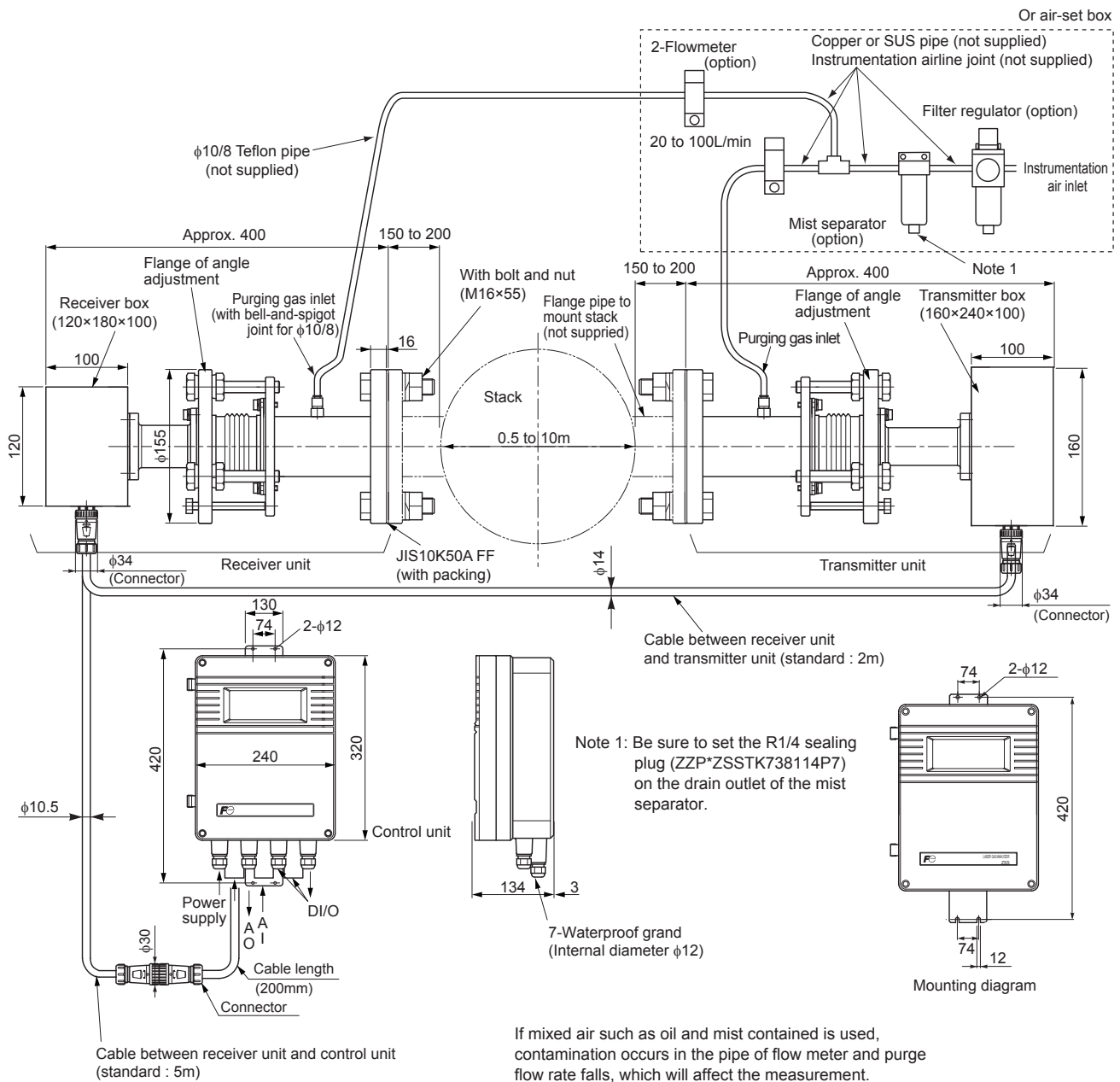

If mixed air such as oil and mist contained is used, contamination occurs in the pipe of flow meter and purge flow rate falls, which will affect the measurement. According to above, maintenance is required frequently and filter may be installed additionally depending on situation. Note) Air or nitrogen purge should be performed if the equipment is installed in a flue whether or not it is operated. If you operate the furnace without purging, it may cause the fatal damage to the optical part.

EXTERNAL CONNECTION DIAGRAM (WHEN THE 10TH CODE IS "0" I.E. ANALOG OUTPUT IS 2 POINTS)

There are two types of output/input terminal.

Power supply terminal

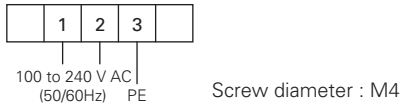

AO terminal

21	22	23	24	25	26	27	28	29	30	31	32	33	34	35	36	37	38	39	40
1	2	3	4	5	6	7	8	9	10	11	12	13	14	15	16	17	18	19	20

Screw diameter : M2 or the equivalent

- | | |
|--------------------------|---------------------------|
| 1 AO1+] | 21 AO2+] |
| 2 AO1-] Analog output 1 | 22 AO2-] Analog output 2 |

AI terminal

21	22	23	24	25	26	27	28	29	30	31	32	33	34	35	36	37	38	39	40
1	2	3	4	5	6	7	8	9	10	11	12	13	14	15	16	17	18	19	20

Screw diameter : M2 or the equivalent

- | | |
|--|---|
| 3 AI1+] | 23 AI4+] |
| 4 AI1-] Analog input 1 | 24 AI4-] Analog input 4 (AI extension board is required) |
| 5 AI2+] | 25 AI5+] |
| 6 AI2-] Analog input 2 | 26 AI5-] Analog input 5 (AI extension board is required) |
| 7 AI3+] | 27 AI6+] |
| 8 AI3-] Analog input 3 (AI extension board is required) | 28 AI6-] Analog input 6 (AI extension board is required) |

DI/DO terminal

21	22	23	24	25	26	27	28	29	30	31	32	33	34	35	36	37	38	39	40
1	2	3	4	5	6	7	8	9	10	11	12	13	14	15	16	17	18	19	20

Screw diameter : M2 or the equivalent

- | | |
|--|--|
| 9 DO1] | 29 DO7] |
| 10 DO1] Low light transmission | 30 DO7] |
| 11 DO2] | 31 DO8] |
| 12 DO2] Device failure | 32 DO8] Power supply off |
| 13 DO3] | 33 DI1] |
| 14 DO3] During hold / during calibration | 34 DI1] Average value reset signal (option) |
| 15 DO4] | 35 DI2] |
| 16 DO4] Outside the range of upper / lower limits | 36 DI2] Switching instantaneous value/moving average value (option) |
| 17 DO5] | 37 DI3] |
| 18 DO5] | 38 DI3] Remote hold (option) |
| 19 DO6] | 39 DI4] |
| 20 DO6] | 40 DI4] |

Note) Unassigned terminal may be connected to internal circuit. So they should not be used as repeating terminals.

EXTERNAL CONNECTION DIAGRAM (WHEN THE 10TH CODE IS "1" I.E. ANALOG OUTPUT IS 4 POINTS)

Power supply terminals

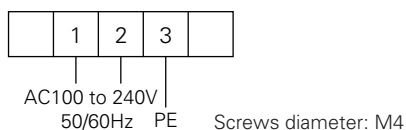

AO terminal

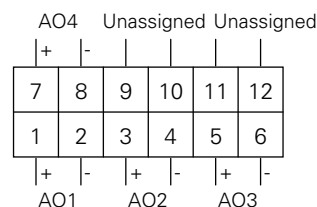

- 1 AO1+ } Analog output 1
- 2 AO1- }
- 3 AO2+ } Analog output 2
- 4 AO2- }
- 5 AO3+ } Analog output 3 (AO extension board is required)
- 6 AO3- }
- 7 AO4+ } Analog output 4 (AO extension board is required)
- 8 AO4- }

AI terminal

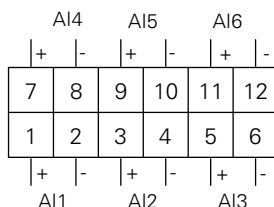

- 1 AI1+ } Analog input 1
- 2 AI1- }
- 3 AI2+ } Analog input 2
- 4 AI2- }
- 5 AI3+ } Analog input 3 (AI extension board is required)
- 6 AI3- }
- 7 AI4+ } Analog input 4 (AI extension board is required)
- 8 AI4- }
- 9 AI5+ } Analog input 5 (AI extension board is required)
- 10 AI5- }
- 11 AI6+ } Analog input 6 (AI extension board is required)
- 12 AI6- }

DI/DO terminal

25	26	27	28	29	30	31	32	33	34	35	36
13	14	15	16	17	18	19	20	21	22	23	24
1	2	3	4	5	6	7	8	9	10	11	12

- 1 DI1 } Average value reset signal (option)
- 2 DI1 } Average value reset signal (option)
- 3 DI2 } Switching instantaneous value/moving average value (option)
- 4 DI2 } Switching instantaneous value/moving average value (option)
- 5 DI3 } Remote hold (option)
- 6 DI3 } Remote hold (option)
- 7 DI4 }
- 8 DI4 }
- 9 DI5 }
- 10 DI5 }
- 13 DO1 } Low light transmission
- 14 DO1 } Low light transmission
- 15 DO2 } Device failure
- 16 DO2 } Device failure
- 17 DO3 } During hold/during calibration
- 18 DO3 } During hold/during calibration
- 19 DO4 } Outside the range of upper/lowerlimits (ch.1)
- 20 DO4 } Outside the range of upper/lowerlimits (ch.1)
- 21 DO5 }
- 22 DO5 }
- 23 DO6 }
- 24 DO6 }
- 25 DO7 }
- 26 DO7 }
- 27 DO8 }
- 28 DO8 } Power supply off
- 29 DO9 }
- 30 DO9 }
- 31 DO10 }
- 32 DO10 }
- 33 DO11 } Outside the range of upper/lowerlimits (ch.2)
- 34 DO11 } Outside the range of upper/lowerlimits (ch.2)

Note) Unassigned terminals may be connected to internal circuit. So they should not be used as repeating terminals.

SCOPE OF DELIVERY

- Receiver box
- Transmitter box
- Control unit
- Angle adjustment mechanical section (required 2 units, one for receiver and the other for transmitter)
- Cable between receiver unit and transmitter unit (specified length)
- Cable between receiver unit and control unit (specified length)
- Standard accessory set, instruction manual

OPTIONAL ITEMS

- Spare parts for one year (ZBN1SS12)
- Calibration gas cell (*1) (*2)
- Cable between receiver unit and transmitter unit (For calibration) (*1)
- Cable between receiver unit and control unit (For calibration) (*1)
- Standard gas (ZBM), pressure regulator (ZBD)
- Recorder (when necessary, Fuji's product type PHL/PHF, etc.)
- Others

*1: One set of the cables and calibration gas cell are necessary for installation and annual maintenance.

*2: Standard length 1m (200mm or 500mm when the measuring range is low concentration)

STANDARD ACCESSORIES

Name	Quantity	Specification
Bolt	8 (16)	M16×55 (70) SUS (*)
Nut	8 (16)	M16 SUS (*)
Spring washer	8 (16)	M16 SUS (*)
Flat washer	8 (16)	M16 SUS (*)
Companion flange packing or flange packing specified for use in high temperature	2	According to flange specifications
Bolt for angle adjustment	6	Hex socket bolt M8 × 70
Power supply fuse	2	
Connecting bolt between receiving unit and transmitter unit	12	Hex socket bolt M5 × 12

(*When "B" or "C" is specified in the 9th digit in a code symbol, quantity is 16 pieces. 8 pieces are attached in other cases.)
 (*When "B", "C" or "D" is specified in the 9th digit, Bolt length is 70mm. It is 55mm in other cases. Inch-sized bolts are not applicable.)

SPARE PARTS FOR ONE YEAR (ZBN1SS12)

Name	Quantity	Remarks
Silicon packing A	2 pieces	For bellows (ZZP*ZSSTK7N3508P1)
O-ring	2 pieces	(ZZP*ZSSTK7P2530P5)

MOUNTING DIMENSIONS (Unit: mm)

Do not install the device in a stack if air purge is not performed.
It may become unusable because the window will get dirty.

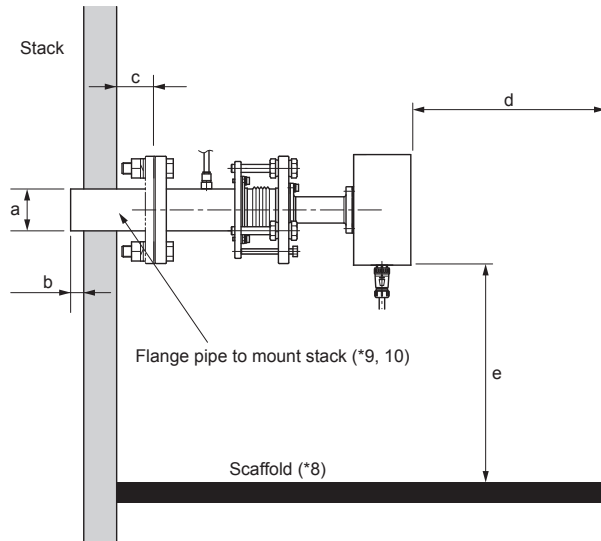

- a: Inner diameter of $\phi 50$ mm or more
- b: 20 to 70mm (*5)
- c: Approximately 200 to 250mm (*6)
- d: 400mm or more (*7)
- e: 500 to 1500mm (*7)

- *5: When used in an environment with high dust, reserve at least 50mm.
- *6: When internal gas temperature is high (500°C or more), reserve the distance of 400mm or more. Note that, adjustable angle range narrows down, so mounting angle of flange pipe to mount stack should be adjusted accurately.
- *7: Sufficiently secure a space for installation which permits easy operation.
- *8: Scaffold is required for the both side of receiver unit and transmitter unit.
- *9: Use a flange provided with a valve where there is a risk of gas injection or the operator may be exposed to dangerous situation.
- *10: Tighten the flange with a torque of $118 \pm 14 \text{N}\cdot\text{m}$. When tightening the flange, apply grease to the bolts (recommendable to use grease containing molybdenum).

ROUGH GUIDE TO MOUNT THE COMPANION FLANGE

When θ is larger than 5° , attach the companion flange with the γ angle $\leq 5^{\circ}$ inside the circumference of radius A.

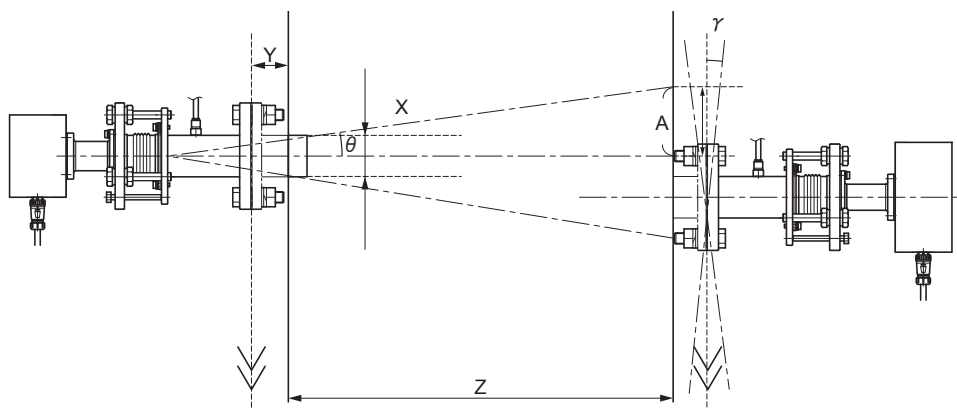

- X: Inner diameter of flange of receiver unit and transmitter unit
- Y: Distance between the outer wall of the duct and each flange of the transmitter unit and the receiver unit
- Z: Length of stack

$$\theta = \tan^{-1} \frac{X}{2(Y + 125)}$$

$$A \approx 0.087 \times (Z + Y + 125)$$

$$\tan 5^{\circ} \approx 0.087$$

Please specify the following items when you contact us for inquiry.

1. Code symbol ZSS
2. Parameter of measured gas

Item	Min. value	Typical value	Max. value
Measured gas concentration			
Temperature (°C)			
Pressure (kPa)			
Flow (m/s)			
Moisture (vol%)			
Dust (mg/m ³ (N))			
Other gas component (vol%/ppm)			
Other gas component (vol%/ppm)			
Other gas component (vol%/ppm)			

3. Stack diameter (Inner diameter) (measured optical path length) A m
4. Length B from stack (inner diameter) to flange B m
5. Length C from stack (inner diameter) to flange C m
6. Cable between receiver unit and control unit. D m
7. Cable between receiver unit and transmitter unit. E m

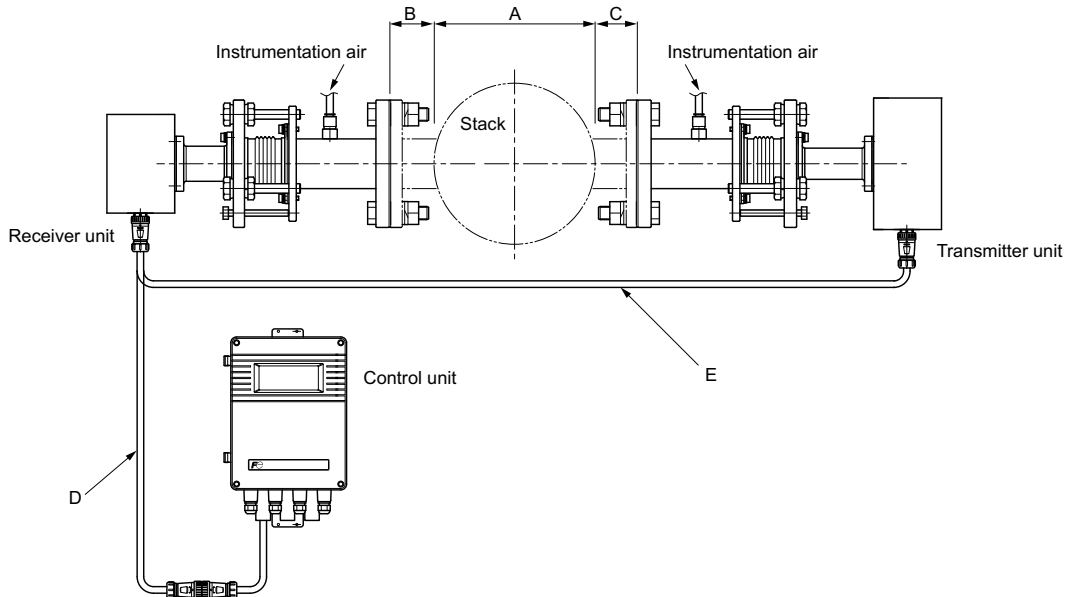

- | | |
|--|-----------------------------|
| 8. Spares for 1-year measurement | no need/necessary |
| 9. Optional items | no need/necessary |
| 10. Output of O ₂ correction value (for only HCl, NH ₃ and CO meter) | no need/necessary |
| 11. Oxygen correction reference value (%) (When "necessary" is selected in 8) | ____% |
| 12. Vibration | no need/necessary (____ G) |

⚠ Caution on Safety

*Before using this product, be sure to read its instruction manual in advance.

JCT Analystechnik GmbH

Werner Heisenberg-Straße 4 A-2700 Wiener Neustadt
 Tel. +43 (0) 2622 / 87201 Fax +43 (0) 2622 / 872011
 E-Mail: sales@jct.at Web: www.jct.at

